

## STEP BY STEP GUIDE (RASPBERRY PI)

Raspberry Pi –

The Raspberry Pi is a credit-card-sized [single-board computer](#) developed in the [UK](#) by the [Raspberry Pi Foundation](#) with the intention of promoting the teaching of basic [computer science](#) in schools. We will be talking about Raspberry Pi (Model B) here. So have a look –

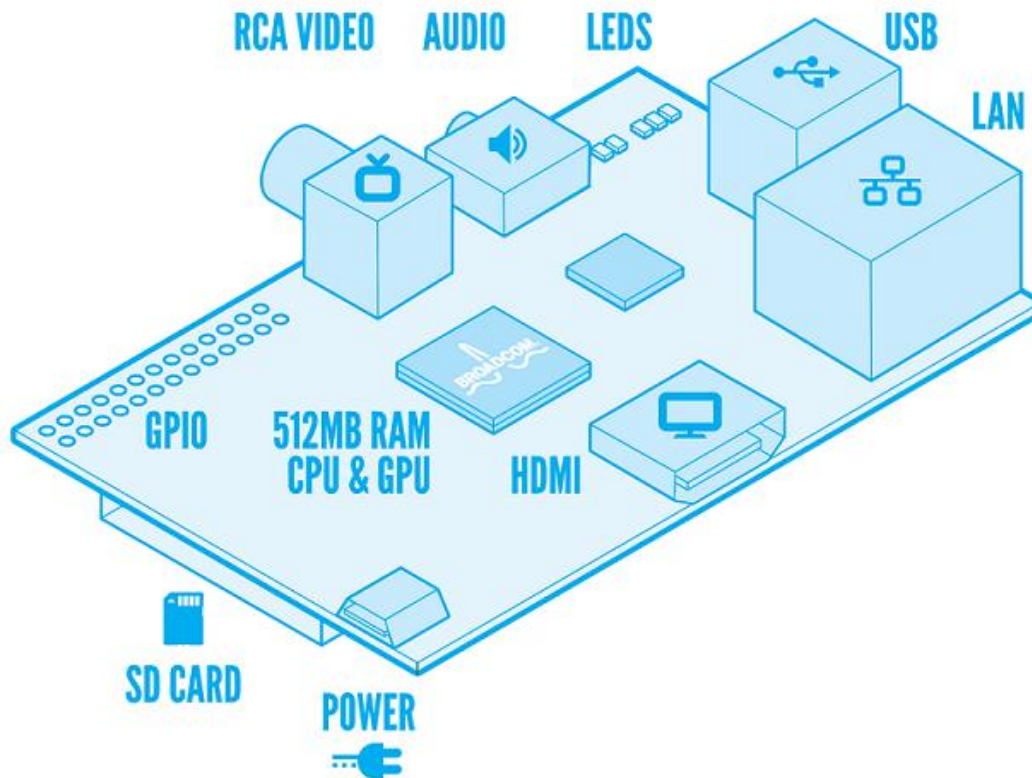

Now I will discuss how to start this for the first time. So Good Luck -

What you need?

- a) Raspberry pi
- b) SD Card (8 GB Preferable)
- c) A power adapter with micro USB male at the end ([700mA -2 A], 5 Volts)

There are many ways you can connect your raspberry pi for graphics. One is to connect with your monitor. If you are going to connect it with monitor, you have 3 options –

- 1) HDMI – HDMI (male) cable ( in case you have monitor with HDMI port)
- 2) AV cable(if you want to connect it to AV input of monitor/TV)
- 3) HDMI – VGA convertor ( If you have VGA port at your monitor end)

Above things are nice to start with but you may also need to explore some additional options if you are going to attach more than 2 USB devices. Well in that case you need –

- d) A USB hub with external power (you can rather use a normal USB hub but then you will face some problem because your raspberry pi is not going to supply that much power for attached devices to work).
- e) If you don't want to use any monitor, another way around is login through SSH (Secure Socket Shell). You can connect to your r-pi through SSH using Wi-Fi adapter with your r-pi. So this way you also need a Wi-Fi adapter. You can also connect your device to network using Ethernet Option. But then, in any case you also need to use monitor for first time to connect your r-pi with appropriate Wi-Fi network.

We only need above devices other than devices (e.g. Keyboard, Mouse, Wi-Fi device etc.) that you want to connect with your r-pi. Now if we are done with our purchase list, Next step is to connect these devices and worry about our software list.

## Connect them all

Before connecting them all and trying to run, we have to do one more thing – Installing a suitable operating system (OS) in SD Card. Well in case of r-pi we have many options available. My bet is on “Raspbian Wheezy”. You can find it @

<http://downloads.raspberrypi.org/download.php?file=/images/raspbian/2012-12-16-wheezy-raspbian/2012-12-16-wheezy-raspbian.zip>

Default login –

Username - pi                      Password – raspberry

While there are some other options available:

Name	Download Link	Login Details
Soft – float Debian “wheezy”	<a href="http://downloads.raspberrypi.org/images/debian/7/2012-08-08-wheezy-armel/2012-08-08-wheezy-armel.zip">http://downloads.raspberrypi.org/images/debian/7/2012-08-08-wheezy-armel/2012-08-08-wheezy-armel.zip</a>	Username – pi Password –raspberry
Arch linux ARM	<a href="http://downloads.raspberrypi.org/images/archlinuxarm/archlinux-hf-2013-02-11/archlinux-hf-2013-02-11.zip">http://downloads.raspberrypi.org/images/archlinuxarm/archlinux-hf-2013-02-11/archlinux-hf-2013-02-11.zip</a>	Username - root Password - root
RISC OS	<a href="http://downloads.raspberrypi.org/images/riscos/riscos-2013-03-19-RC8/riscos-2013-03-19-RC8.zip">http://downloads.raspberrypi.org/images/riscos/riscos-2013-03-19-RC8/riscos-2013-03-19-RC8.zip</a>	

Now as you have downloaded OS image file, you need to extract it and install it on r-pi. For installing you need a tool called **Win32DiskImager** (for Windows platform). You can download it @<https://launchpad.net/win32-image-writer/+download>

After installing above software just put your SD Card in laptop SD port and run this software. You will see a screen –

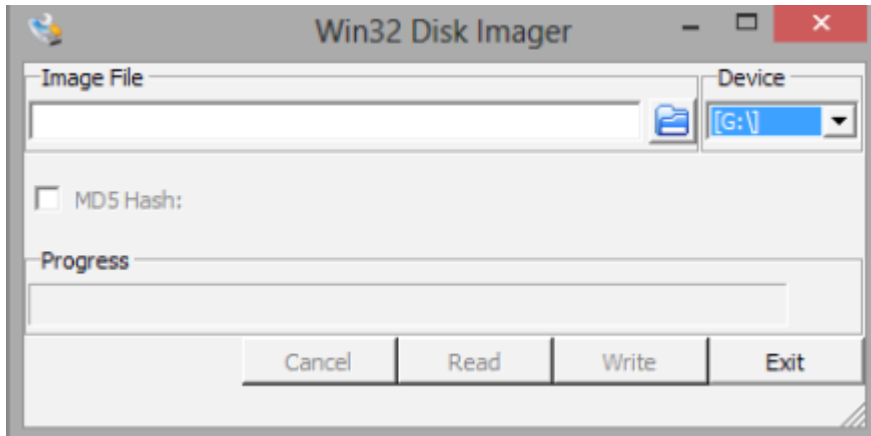

- a) Select your SD card drive from dropdown at upper-right corner.
- b) Click on folder icon which is just left to it and browse to your OS image location & select it.
- c) Click on Write button at the bottom. In few minutes you will get OS image written on SD card.

Now it is time connect all the above devices.

## Starting your r-pi for first time

If you have connected all these Devices and ready to run your r-pi for the first time, then congratulations to you. Lets just forget about OS thing and one thing you should do straight forward is **Expanding your SD Card**. Reason behind this is that when you loaded image of OS in SD card, originally it is loaded into 2GB space from your whole SD Card. Other 6 GB is inaccessible. Lets just make that 6 GB useful.

- a) On your first boot you will see a Raspi-Config window.
- b) You can also change timezone and locale if you want.
- c) Now select expand\_rootfs and click on yes option for reboot.

Enough, Now we are ready to start our r-pi for the first time. But one thing we still need to care about is "What option we have chosen for accessing r-pi?"

CASE 1 -

In case of Monitor, It is little easy to start with. You just have to login with username "pi" & password "raspberrry".

To enter GUI just type "startx" at terminal window and press ENTER.

CASE 2 -

In case of SSH login we still have to go through "CASE 1" for the first time –

- a) Click on Wi-Fi Config icon present on your desktop. You will get something like –

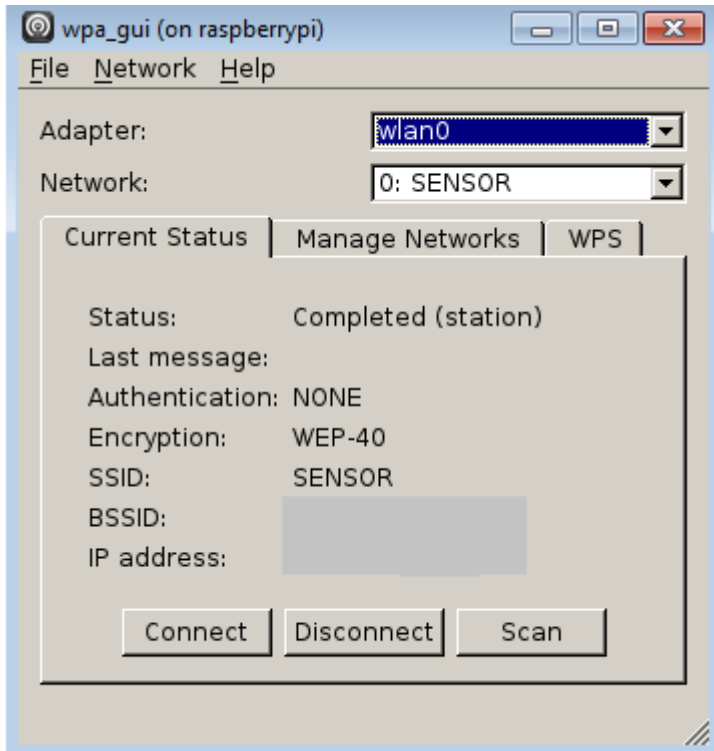

- b) Click on “Scan” and select appropriate network and type its credentials.
- c) Type ifconfig in linux terminal and list will come in front of you. Note IP Address against “inet addr:” header.
- d) Now we are ready to login through SSH. Start Chrome (if using Google Chrome’s Secure Shell; other software if you are using that).

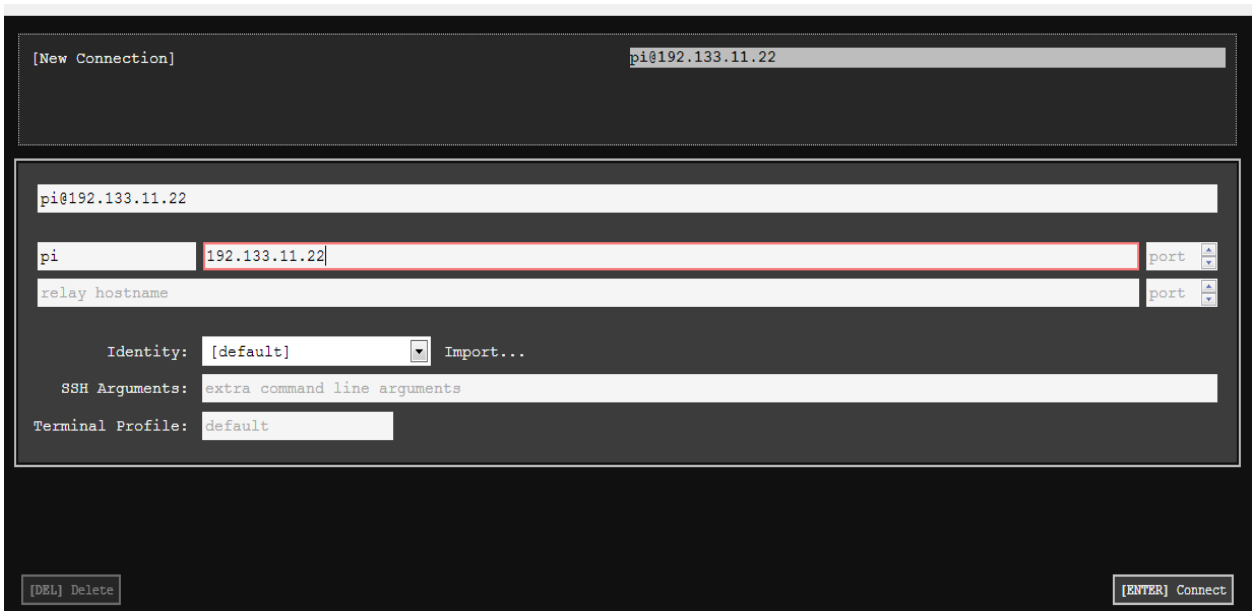

- e) If you don’t want to use Wi-Fi medium and want to try Ethernet cable, that’s ok. So have a look-

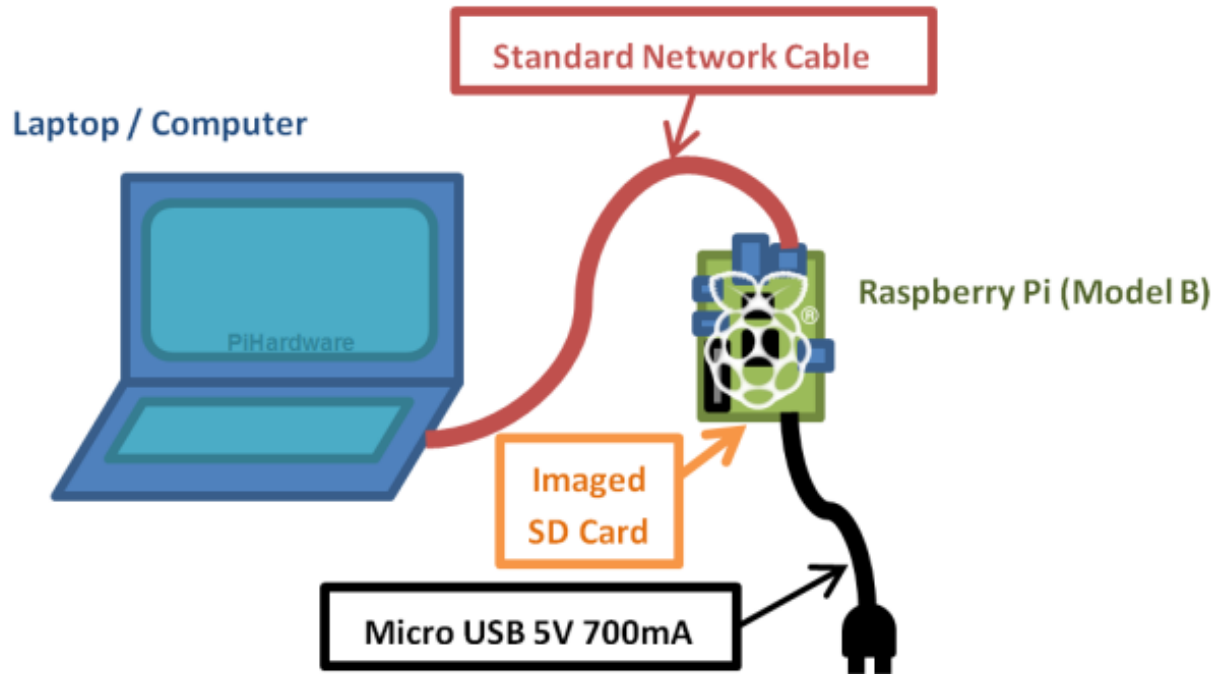

- f) Type username (pi) and IP (your raspberry ip address) and port (22 : default) and press ENTER. It will ask for password ("raspberrypi" – default). Type it and you have now successfully logged in.

*Inderpal Singh*

Inderpal Singh  
Software Engineer(IIITD)  
New Delhi, India  
luv.rajan07@gmail.com